



Low-Cost, UCSP/SOT23, Micropower, High-Side Current-Sense Amplifier with Voltage Output

MAX4372T/F/H

General Description

The MAX4372 low-cost, precision, high-side current-sense amplifier is available in a tiny, space-saving SOT23-5-pin package. Offered in three gain versions (T = 20V/V, F = 50V/V, and H = 100V/V), this device operates from a single 2.7V to 28V supply and consumes only 30 μ A. It features a voltage output that eliminates the need for gain-setting resistors and is ideal for today's notebook computers, cell phones, and other systems where battery/DC current monitoring is critical.

High-side current monitoring is especially useful in battery-powered systems since it does not interfere with the ground path of the battery charger. The input common-mode range of 0 to 28V is independent of the supply voltage and ensures that the current-sense feedback remains viable even when connected to a 2-cell battery pack in deep discharge.

The user can set the full-scale current reading by choosing the device (T, F, or H) with the desired voltage gain and selecting the appropriate external sense resistor. This capability offers a high level of integration and flexibility, resulting in a simple and compact current-sense solution. For higher bandwidth applications, refer to the MAX4173T/F/H data sheet.

Applications

Power-Management Systems
 General-System/Board-Level Current Monitoring
 Notebook Computers
 Portable/Battery-Powered Systems
 Smart-Battery Packs/Chargers
 Cell Phones
 Precision-Current Sources

Pin Configurations

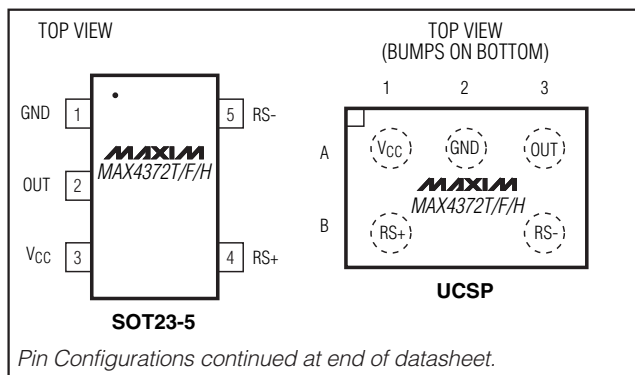

Features

- ◆ Low-Cost, Compact Current-Sense Solution
- ◆ 30 μ A Supply Current
- ◆ 2.7V to 28V Operating Supply
- ◆ 0.18% Full-Scale Accuracy
- ◆ 0.3mV Input Offset Voltage
- ◆ Low 1.5 Ω Output Impedance
- ◆ Three Gain Versions Available
 - 20V/V (MAX4372T)
 - 50V/V (MAX4372F)
 - 100V/V (MAX4372H)
- ◆ Wide 0 to 28V Common-Mode Range, Independent of Supply Voltage
- ◆ Available in a Space-Saving 5-Pin SOT23 Package and 3 x 2 UCSP™ (1mm x 1.5mm) Package

Ordering Information

PART	TEMP RANGE	PIN-PACKAGE	TOP MARK
MAX4372TEUK-T	-40°C to +85°C	5 SOT23-5	ADIU
MAX4372TESA	-40°C to +85°C	8 SO	—
MAX4372TEBT-T	-40°C to +85°C	3 x 2 UCSP	ACX

Note: Gain values are as follows: 20V/V for the T version, 50V/V for the F version, and 100V/V for the H version.

Ordering Information continued at end of datasheet.

Typical Operating Circuit

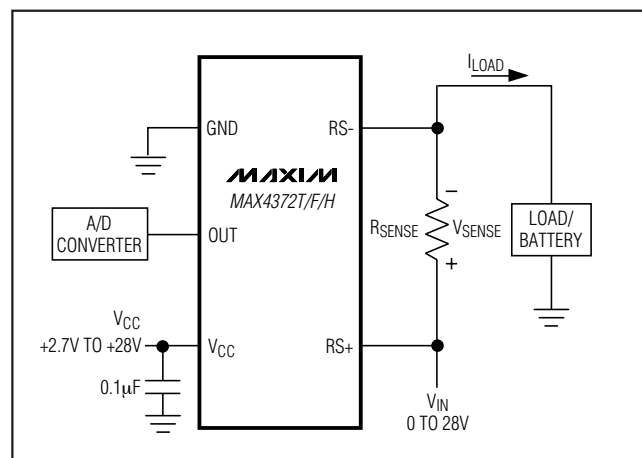

UCSP is a trademark of Maxim Integrated Products, Inc.



Low-Cost, UCSP/SOT23, Micropower, High-Side Current-Sense Amplifier with Voltage Output

ABSOLUTE MAXIMUM RATINGS

V _{CC} , RS+, RS- to GND	-0.3V to +30V
OUT to GND	-0.3V to +15V
Differential Input Voltage (V _{RS+} - V _{RS-})	±0.3V
Current into Any Pin	±10mA
Continuous Power Dissipation (T _A = +70°C)	
5-Pin SOT23 (derate 7.1mW/°C above +70°C)	571mW
8-Pin SO (derate 5.88mW/°C above +70°C)	471mW
3 x 2 UCSP (derate 3.4mW/°C above +70°C)	273.2mW

Operating Temperature Range	-40°C to +85°C
Storage Temperature Range	-65°C to +150°C
Lead Temperature (soldering, 10s)	+300°C
Bump Temperature (soldering)	
Infrared (15s)	+200°C
Vapor Phase (20s)	+215°C

Stresses beyond those listed under "Absolute Maximum Ratings" may cause permanent damage to the device. These are stress ratings only, and functional operation of the device at these or any other conditions beyond those indicated in the operational sections of the specifications is not implied. Exposure to absolute maximum rating conditions for extended periods may affect device reliability.

ELECTRICAL CHARACTERISTICS

(V_{RS+} = 0 to 28V, V_{CC} = 2.7V to 28V, V_{SENSE} = 0, R_{LOAD} = 1MΩ, T_A = T_{MIN} to T_{MAX}, unless otherwise noted. Typical values are at T_A = +25°C.) (Note 1)

PARAMETER	SYMBOL	CONDITIONS	MIN	TYP	MAX	UNITS
Operating Voltage Range (Note 2)	V _{CC}		2.7		28	V
Common-Mode Input Range (Note 3)	V _{CMR}		0		28	V
Common-Mode Rejection	CMR	V _{RS+} > 2V		85		dB
Supply Current	I _{CC}	V _{RS+} > 2V, V _{SENSE} = 5mV		30	60	μA
Leakage Current	I _{RS+} , I _{RS-}	V _{CC} = 0		0.05	1.2	μA
Input Bias Current	I _{RS+}	V _{RS+} > 2V	0		1	μA
		V _{RS+} ≤ 2V	-25		2	
	I _{RS-}	V _{RS+} > 2V	0		2	
		V _{RS+} ≤ 2V	-50		2	
Full-Scale Sense Voltage (Note 4)	V _{SENSE}	Gain = 20V/V or 50V/V		150		mV
		Gain = 100V/V		100		
Input Offset Voltage (Note 5)	V _{OS}	T _A = +25°C V _{CC} = V _{RS+} = 12V	MAX4372_ESA	0.3	±0.8	mV
			MAX4372_EUK, _EBT	0.3	±1.3	
		T _A = T _{MIN} to T _{MAX} V _{CC} = V _{RS+} = 12V	MAX4372_ESA		±1.1	
			MAX4372_EUK, _EBT		±1.9	
Full-Scale Accuracy (Note 5)		V _{SENSE} = 100mV, V _{CC} = 12V, V _{RS+} = 12V, T _A = +25°C (Note 7)		±0.18	±3	%
Total OUT Voltage Error (Note 6)		V _{SENSE} = 100mV, V _{CC} = 12V, V _{RS+} = 12V (Note 7)			±6	%
		V _{SENSE} = 100mV, V _{CC} = 28V, V _{RS+} = 28V (Note 7)		±0.15	±7	
		V _{SENSE} = 100mV, V _{CC} = 12V, V _{RS+} = 0.1V (Note 7)		±1	±28	
		V _{SENSE} = 6.25mV, V _{CC} = 12V, V _{RS+} = 12V (Note 8)		±0.15		
OUT Low Voltage		V _{CC} = 2.7V	I _{OUT} = 10μA	2.6		mV
			I _{OUT} = 100μA	9	65	
OUT High Voltage	V _{CC} - V _{OH}	V _{CC} = 2.7V, I _{OUT} = -500μA		0.1	0.25	V

Low-Cost, UCSP/SOT23, Micropower, High-Side Current-Sense Amplifier with Voltage Output

ELECTRICAL CHARACTERISTICS (continued)

($V_{RS+} = 0$ to 28V, $V_{CC} = 2.7V$ to 28V, $V_{SENSE} = 0$, $R_{LOAD} = 1M\Omega$, $T_A = T_{MIN}$ to T_{MAX} , unless otherwise noted. Typical values are at $T_A = +25^\circ C$.) (Note 1)

PARAMETER	SYMBOL	CONDITIONS		MIN	TYP	MAX	UNITS
-3dB Bandwidth	BW	$V_{RS+} = 12V$, $V_{CC} = 12V$, $C_{LOAD} = 10pF$	$V_{SENSE} = 20mV$, gain = 20V/V		275		kHz
			$V_{SENSE} = 20mV$, gain = 50V/V		200		
			$V_{SENSE} = 20mV$, gain = 100V/V		110		
			$V_{SENSE} = 6.25mV$		50		
Gain			MAX4372T		20		V/V
			MAX4372F		50		
			MAX4372H		100		
Gain Accuracy		$V_{SENSE} = 20mV$ to 100mV	$T_A = +25^\circ C$		± 0.25	± 2.5	%
			$T_A = -40^\circ C$ to $+85^\circ C$			± 5.5	
OUT Settling Time to 1% of Final Value		Gain = 20V/V, $V_{CC} = 12V$, $V_{RS+} = 12V$, $C_{LOAD} = 10pF$	$V_{SENSE} = 6.25mV$ to 100mV		20		μs
			$V_{SENSE} = 100mV$ to 6.25mV		20		
Capacitive-Load Stability		No sustained oscillations			1000		pF
OUT Output Resistance	R_{OUT}	$V_{SENSE} = 100mV$			1.5		Ω
Power-Supply Rejection	PSR	$V_{OUT} = 2V$, $V_{RS+} > 2V$		75	85		dB
Power-Up Time to 1% of Final Value		$V_{CC} = 12V$, $V_{RS+} = 12V$, $V_{SENSE} = 100mV$, $C_{LOAD} = 10pF$			0.5		ms
Saturation Recovery Time (Note 9)		$V_{CC} = 12V$, $V_{RS+} = 12V$, $C_{LOAD} = 10pF$			0.1		ms

Note 1: All devices are 100% production tested at $T_A = +25^\circ C$. All temperature limits are guaranteed by design.

Note 2: Guaranteed by PSR test.

Note 3: Guaranteed by OUT Voltage Error test.

Note 4: Output voltage is internally clamped not to exceed 12V.

Note 5: V_{OS} is extrapolated from the gain accuracy tests.

Note 6: Total OUT voltage error is the sum of gain and offset voltage errors.

Note 7: Measured at $I_{OUT} = -500\mu A$ ($R_{LOAD} = 4k\Omega$ for gain = 20V/V, $R_{LOAD} = 10k\Omega$ for gain = 50V/V, $R_{LOAD} = 20k\Omega$ for gain = 100V/V).

Note 8: 6.25mV = 1/16 of 100mV full-scale voltage (C/16).

Note 9: The device will not reverse phase when overdriven.

Low-Cost, UCSP/SOT23, Micropower, High-Side Current-Sense Amplifier with Voltage Output

Typical Operating Characteristics

($V_{CC} = 12V$, $V_{RS+} = 12V$, $V_{SENSE} = 100mV$, $T_A = +25^\circ C$, unless otherwise noted.)

SUPPLY CURRENT vs. SUPPLY VOLTAGE

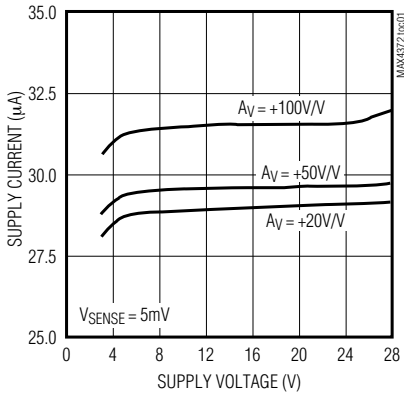

SUPPLY CURRENT vs. TEMPERATURE

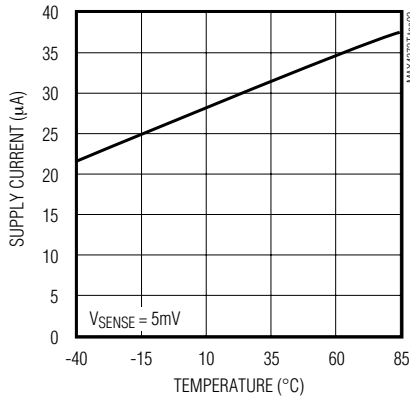

SUPPLY CURRENT vs. COMMON-MODE VOLTAGE

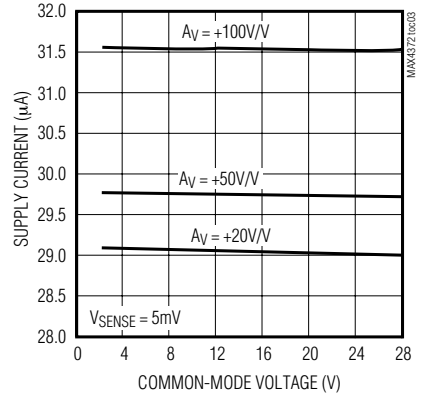

TOTAL OUTPUT ERROR vs. SUPPLY VOLTAGE

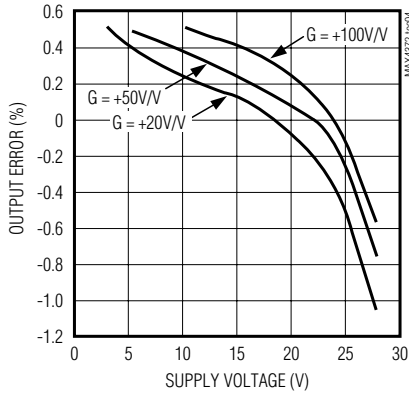

TOTAL OUTPUT ERROR vs. VSENSE

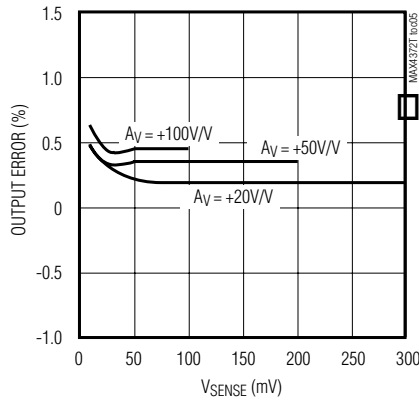

POWER-SUPPLY REJECTION vs. FREQUENCY

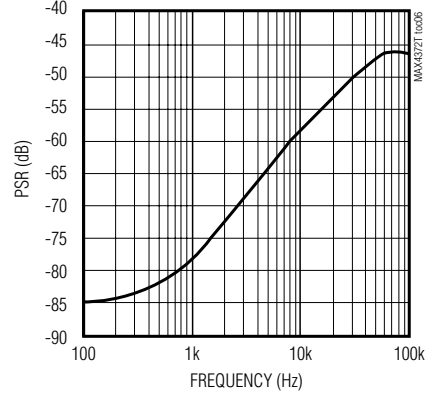

TOTAL OUTPUT ERROR vs. COMMON-MODE VOLTAGE

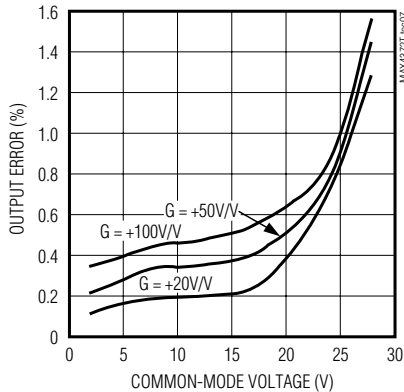

GAIN ACCURACY vs. TEMPERATURE

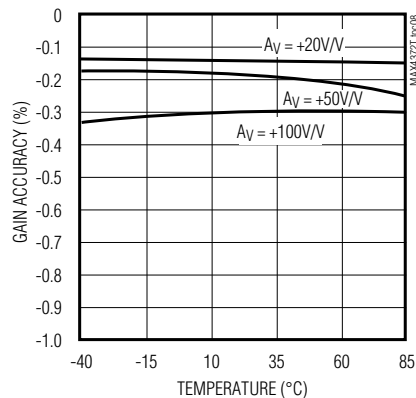

TOTAL OUTPUT ERROR vs. TEMPERATURE

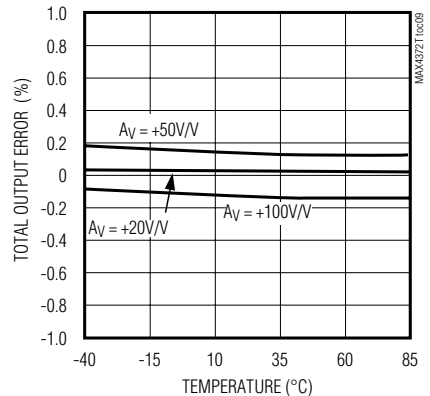

Low-Cost, UCSP/SOT23, Micropower, High-Side Current-Sense Amplifier with Voltage Output

Typical Operating Characteristics (continued)

($V_{CC} = 12V$, $V_{RS+} = 12V$, $V_{SENSE} = 100mV$, $T_A = +25^{\circ}C$, unless otherwise noted.)

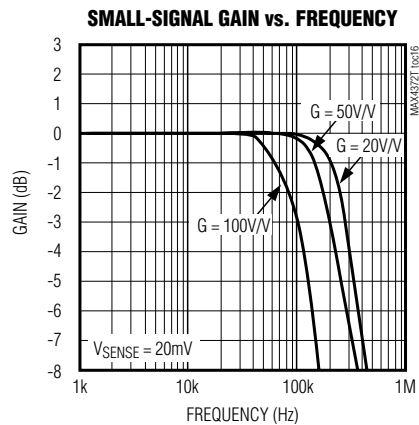
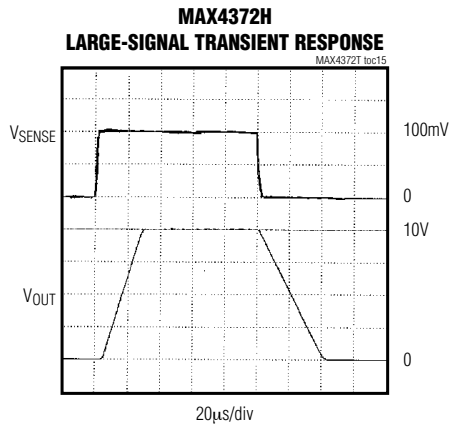
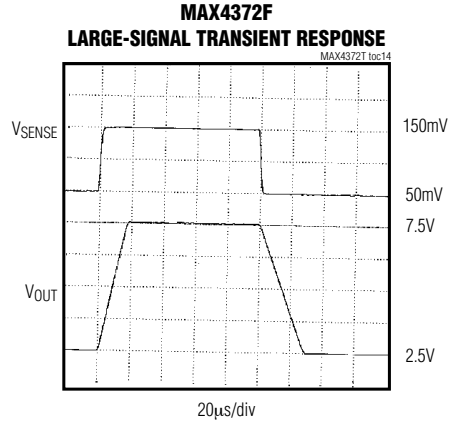
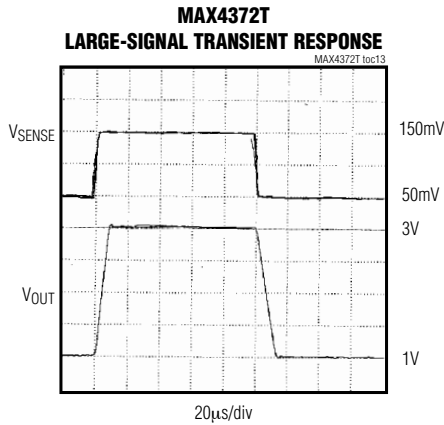
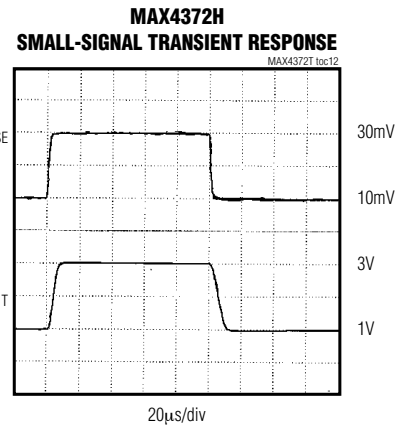
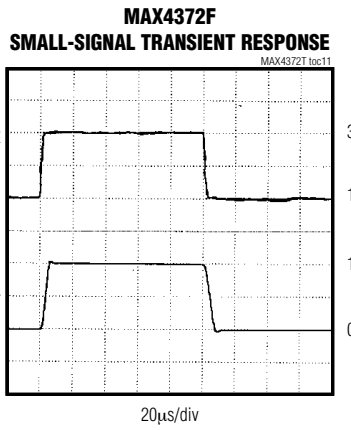
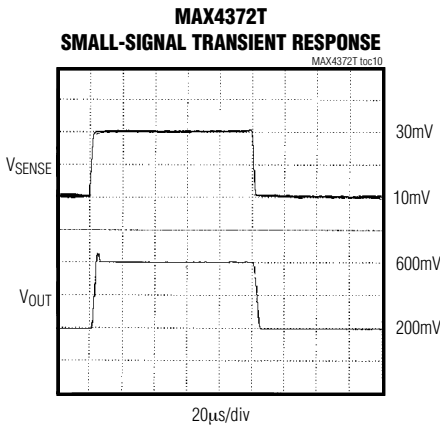

Low-Cost, UCSP/SOT23, Micropower, High-Side Current-Sense Amplifier with Voltage Output

Pin Description

PIN			NAME	FUNCTION
SOT23	SO	UCSP		
1	3	A2	GND	Ground
2	4	A3	OUT	Output Voltage. V_{OUT} is proportional to the magnitude of V_{SENSE} ($V_{RS+} - V_{RS-}$).
3	1	A1	V_{CC}	Supply Voltage. Use at least a 0.1 μ F capacitor to decouple V_{CC} from fast transients.
4	8	B1	RS+	Power Connection to the External Sense Resistor
5	6	B3	RS-	Load-Side Connection to the External Sense Resistor
—	2, 5, 7	—	N.C.	No Connection. Not internally connected.

Detailed Description

The MAX4372 high-side current-sense amplifier features a 0 to 28V input common-mode range that is independent of supply voltage. This feature allows the monitoring of current flow out of a battery in deep discharge, and also enables high-side current sensing at voltages far in excess of the supply voltage (V_{CC}).

Current flows through the sense resistor, generating a sense voltage (Figure 1). Since A1's inverting input is high impedance, the voltage on the negative terminal equals $V_{IN} - V_{SENSE}$. A1 forces its positive terminal to match its negative terminal; therefore, the voltage across R_{G1} ($V_{IN} - V_{1-}$) equals V_{SENSE} . This creates a current to flow through R_{G1} equal to V_{SENSE} / R_{G1} . The transistor and current mirror amplify the current by a factor of β . This makes the current flowing out of the current mirror equal to:

$$I_M = \beta V_{SENSE} / R_{G1}$$

A2's positive terminal presents high impedance, so this current flows through R_{GD} , with the following result:

$$V_{2+} = R_{GD} \beta \cdot V_{SENSE} / R_{G1}$$

R_1 and R_2 set the closed-loop gain for A2, which amplifies V_{2+} , yielding:

$$V_{OUT} = R_{GD} \cdot \beta \cdot V_{SENSE} / R_{G1} (1 + R_2 / R_1)$$

The gain of the device equals:

$$\frac{V_{OUT}}{V_{SENSE}} = R_{GD} \cdot \beta (1 + R_2 / R_1) / R_{G1}$$

Applications Information

Recommended Component Values

The MAX4372 operates over a wide variety of current ranges with different sense resistors. Table 1 lists common resistor values for typical operation of the MAX4372.

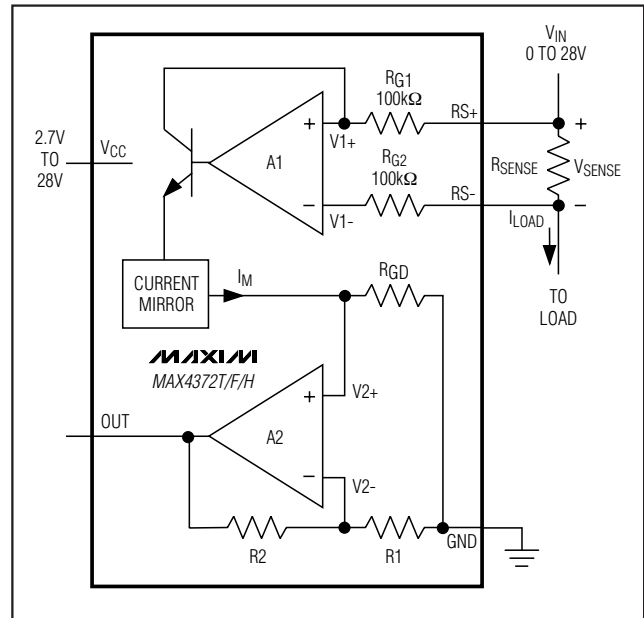

Figure 1. Functional Diagram

Choosing RSENSE

Given the gain and maximum load current, select R_{SENSE} such that $V_{CC} - V_{OUT}$ does not exceed 0.25V and V_{OUT} does not exceed 10V. To measure lower currents more accurately, use a high value for R_{SENSE} . A higher value develops a higher sense voltage, which overcomes offset voltage errors of the internal current amplifier.

In applications monitoring very high current, ensure R_{SENSE} is able to dissipate its own I^2R losses. If the resistor's rated power dissipation is exceeded, its value may drift or it may fail altogether, causing a differential voltage across the terminals in excess of the absolute maximum ratings.

Low-Cost, UCSP/SOT23, Micropower, High-Side Current-Sense Amplifier with Voltage Output

Table 1. Recommended Component Values

FULL-SCALE LOAD CURRENT, I _{LOAD} (A)	CURRENT-SENSE RESISTOR, R _{SENSE} (mΩ)	GAIN (V/V)	FULL-SCALE OUTPUT VOLTAGE (FULL-SCALE V _{SENSE} = 100mV), V _{OUT} (V)
0.1	1000	20	2.0
		50	5.0
		100	10.0
1	100	20	2.0
		50	5.0
		100	10.0
5	20	20	2.0
		50	5.0
		100	10.0
10	10	20	2.0
		50	5.0
		100	10.0

Using a PC Board Trace as R_{SENSE}

If the cost of R_{SENSE} is an issue and accuracy is not critical, use the alternative solution shown in Figure 2. This solution uses copper PC board traces to create a sense resistor. The resistivity of a 0.1-inch-wide trace of 2-ounce copper is about 30mΩ/ft. The resistance temperature coefficient of copper is fairly high (approximately 0.4%/°C), so systems that experience a wide temperature variance must compensate for this effect. In addition, self-heating will introduce a nonlinearity error. Do not exceed the maximum power dissipation of the copper trace.

For example, the MAX4372T (with a maximum load current of 10A and an R_{SENSE} of 5mΩ) creates a full-scale V_{SENSE} of 50mV that yields a maximum V_{OUT} of 1V. R_{SENSE}, in this case, requires about 2 inches of 0.1-inch-wide copper trace.

UCSP Applications Information

For the latest application details on UCSP construction, dimensions, tape carrier information, printed circuit board techniques, bump-pad layout, and recommended reflow temperature profile, as well as the latest information on reliability testing results, go to the Maxim's website at www.maxim-ic.com/ucsp to find the Application Note: UCSP—A Wafer-Level Chip-Scale Package.

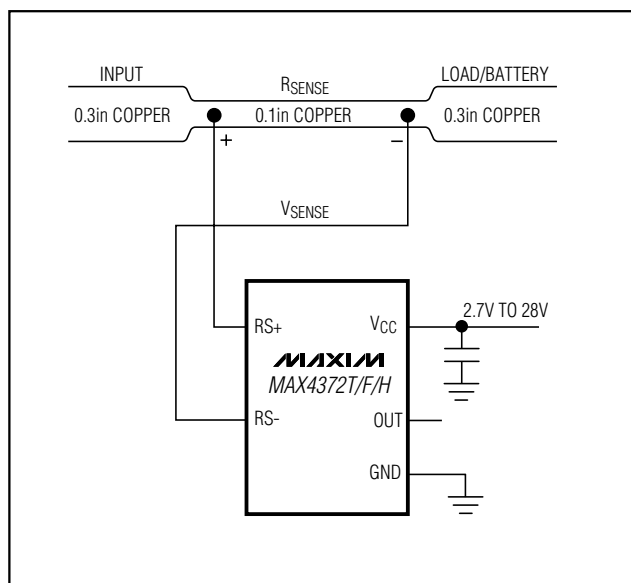

Figure 2. Connections Showing Use of PC Board

Low-Cost, UCSP/SOT23, Micropower, High-Side Current-Sense Amplifier with Voltage Output

Ordering Information (continued)

PART	TEMP RANGE	PIN-PACKAGE	TOP MARK
MAX4372FEUK-T	-40°C to +85°C	5 SOT23-5	ADIV
MAX4372FESA	-40°C to +85°C	8 SO	—
MAX4372FEBT-T	-40°C to +85°C	3 x 2 UCSP	ACY
MAX4372HEUK-T	-40°C to +85°C	5 SOT23-5	ADIW
MAX4372HESA	-40°C to +85°C	8 SO	—
MAX4372HEBT-T	-40°C to +85°C	3 x 2 UCSP	ACZ

Chip Information

TRANSISTOR COUNT: 225
 PROCESS: BICMOS

Pin Configurations (continued)

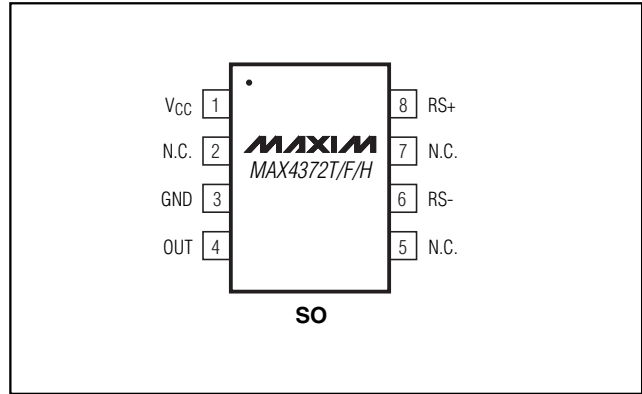

Package Information

(The package drawing(s) in this data sheet may not reflect the most current specifications. For the latest package outline information, go to www.maxim-ic.com/packages.)

TOP VIEW

COMMON DIMENSIONS		VARIABLE DIMENSIONS		DEPOPULATED SOLDER BALLS	
		D	E		
A	0.62±0.05-0.08	B6-1	1.00±0.05	1.52±0.05	NONE
A1	0.29±0.02	B6-2	1.00±0.05	1.52±0.05	B2
A2	0.33 REF.	B6-3	1.05±0.05	1.57±0.05	NONE
b	∅0.35±0.03	B6-4	1.05±0.05	1.57±0.05	B2
D1	0.50 BASIC	B6-5	0.97±0.05	1.46±0.05	NONE
E1	1.00 BASIC	B6-6	1.16±0.05	1.57±0.05	NONE
e	0.50 BASIC				
SD	0.25 BASIC				
SE	0.00 BASIC				

NOTES:

- ALL DIMENSIONS ARE IN MILLIMETERS.
- PRODUCT MARKING: NUMBER OF CHARACTERS AND LINES VARY PER PRODUCT.

BOTTOM VIEW

SIDE VIEW

PROPRIETARY INFORMATION

TITLE: PACKAGE OUTLINE, 3x2 UCSP

APPROVAL: _____ DOCUMENT CONTROL NO. 21-0097 REV. G 1/1

Note: MAX4372_EBT uses package code B6-2.

Low-Cost, UCSP/SOT23, Micropower, High-Side Current-Sense Amplifier with Voltage Output

Package Information (continued)

(The package drawing(s) in this data sheet may not reflect the most current specifications. For the latest package outline information, go to www.maxim-ic.com/packages.)

MAX4372T/F/H

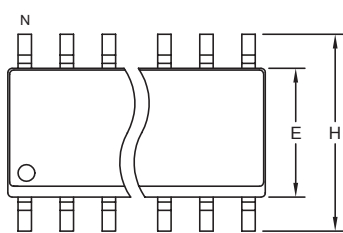

TOP VIEW

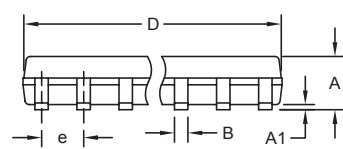

FRONT VIEW

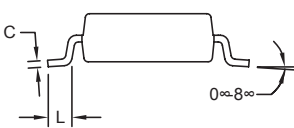

SIDE VIEW

NOTES:
 1. D&E DO NOT INCLUDE MOLD FLASH.
 2. MOLD FLASH OR PROTRUSIONS NOT TO EXCEED 0.15mm (.006").
 3. LEADS TO BE COPLANAR WITHIN 0.10mm (.004").
 4. CONTROLLING DIMENSION: MILLIMETERS.
 5. MEETS JEDEC MS012.
 6. N = NUMBER OF PINS.

DIM	INCHES		MILLIMETERS	
	MIN	MAX	MIN	MAX
A	0.053	0.069	1.35	1.75
A1	0.004	0.010	0.10	0.25
B	0.014	0.019	0.35	0.49
C	0.007	0.010	0.19	0.25
e	0.050 BSC		1.27 BSC	
E	0.150	0.157	3.80	4.00
H	0.228	0.244	5.80	6.20
L	0.016	0.050	0.40	1.27

VARIATIONS:

DIM	INCHES		MILLIMETERS		N	MS012
	MIN	MAX	MIN	MAX		
D	0.189	0.197	4.80	5.00	8	AA
D	0.337	0.344	8.55	8.75	14	AB
D	0.386	0.394	9.80	10.00	16	AC



PROPRIETARY INFORMATION
 TITLE: PACKAGE OUTLINE, .150" SOIC
 APPROVAL: _____ DOCUMENT CONTROL NO. 21-0041 REV. B 1/1

Low-Cost, UCSP/SOT23, Micropower, High-Side Current-Sense Amplifier with Voltage Output

Package Information (continued)

(The package drawing(s) in this data sheet may not reflect the most current specifications. For the latest package outline information, go to www.maxim-ic.com/packages.)

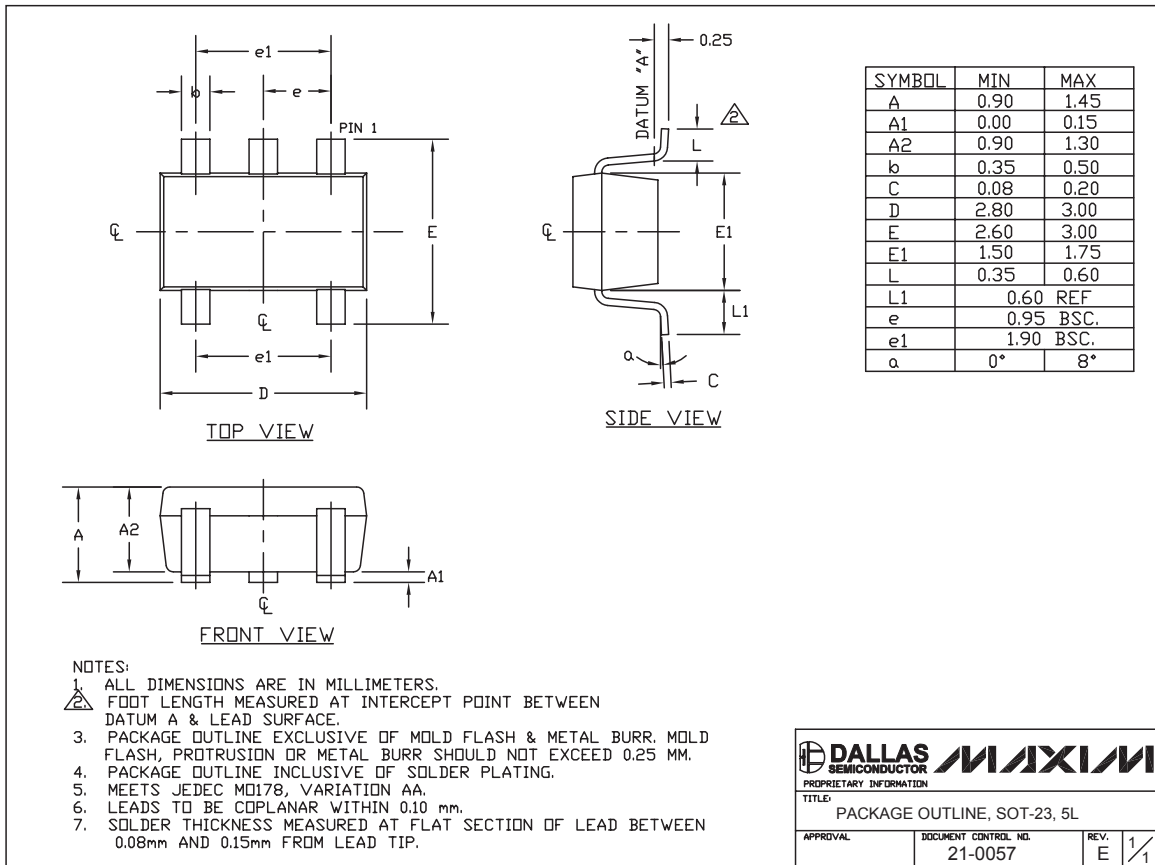

SOT-23 5L EFS

DALLAS SEMICONDUCTOR **MAXIM**

PROPRIETARY INFORMATION

TITLE: PACKAGE OUTLINE, SOT-23, 5L

APPROVAL	DOCUMENT CONTROL NO. 21-0057	REV. E	1/1
----------	---------------------------------	-----------	-----

Maxim cannot assume responsibility for use of any circuitry other than circuitry entirely embodied in a Maxim product. No circuit patent licenses are implied. Maxim reserves the right to change the circuitry and specifications without notice at any time.

10 Maxim Integrated Products, 120 San Gabriel Drive, Sunnyvale, CA 94086 408-737-7600